



# SPK1 - Manual Control

General Assembly, Installation, and Operation Instructions for use with  
Natural and Propane Gas Burners; F, FX, CS, CXF, TNA



Report 10-038

# Rasmussen GAS LOGS & GRILLS

12028 E. PHILADELPHIA ST. WHITTIER CA 90601 U.S.A.  
www.rasmussen.biz

FORM: SPK1-2-17

## ATTENTION! READ INSTRUCTIONS CAREFULLY BEFORE ASSEMBLY

### REQUIRED TOOLS AND MATERIALS

Adjustable Wrench, Pipe Wrench, Flat Head Screwdriver, Phillips Screwdriver, Pipe Sealing compound  
(Only required if fittings not already prepared with pre-wrapped Teflon thread tape).

### SPK1 PARTS LIST

- |  |  |
|--|--|
| 1. Air Mixer for LP Gas Burner Inlet Assembly (MA2)      | 5. 10-32 x 3/8 bolts (qty. 3)                    |
| 2. LP Burner Orifice #53, 51, 49 and 45 (01-XX)          | 6. 10-32 Hex nut                                 |
| 3. Internally Tapped 3/8 Flared x 3/8 MIP Elbow (A2T-Z2) | 7. Valve Knob Extender (K4)                      |
| 4a. Pilot Support Bracket for F/FX & LC burners (PB-1)   | 8. 10" flex Connector (SSCB-10)                  |
| 4b. Pilot Support Bracket for CXF burners (PB-2)         | 9. Pilot-Thermocouple Assembly (J95R -NG or -LP) |
| 4c. Thermocouple Heat shield (PB-4) (Page 3)             | 10. Manual Safety Valve (V15SM)                  |
| 4d. Pilot Support Bracket for CS burner (PB-3)           | 11. Heat Shield (HS-CMV)                         |
| 4e. Pilot Support Bracket for TNA burner (PB7)           | 12. Valve Knob (JK2)                             |

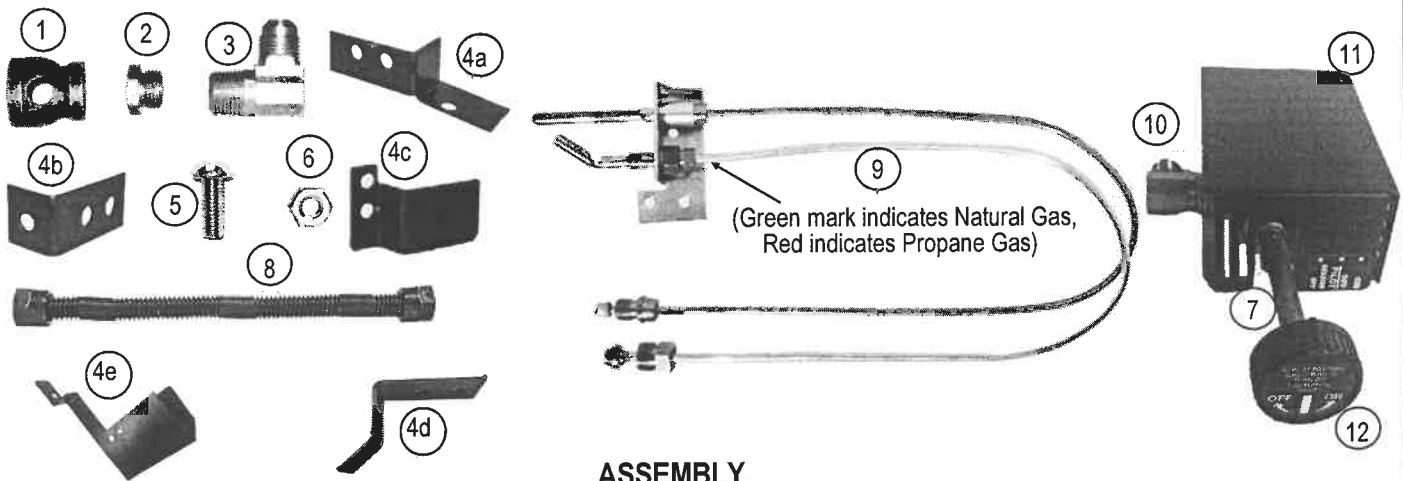

### ASSEMBLY

#### STEP ONE: BURNER PAN FITTINGS (Figure 1; page 2)

**NOTE:** If fittings do not come pre-wrapped with teflon threaded tape, pipe compound or tape must be applied to all non-flared threads. Do Not use tape or compound on flared threads.

1. Ensure that the **BURNER PLUG** (Figure 1A.) is inserted into the opposite end of the **BURNER PIPE** (Figure 1B) and wrench tightened.
2. Thread the Natural Gas or Propane Burner Pan Inlet Assembly into the **BURNER PAN** (Figure 1C).
  - **Natural Gas Burners (NG)** (F, FX, CS, CXF, TNA) Insert the **BURNER ORIFICE** (Figure 1D) into the **INTERNALLY TAPPED 3/8 FLARED x 3/8 MIP ELBOW** (Figure 1E) and wrench tighten. (Orifices and Fittings are provided with the Burner Pan)
  - **Propane Burners (LP)** (F, FX, CS, CXF, TNA-LP) requires **MA2** (Figure 1F) or **MA-** (Figure 1G) **AIR MIXER ASSEMBLY**. Insert the Internally Tapped 3/8 Flared x 3/8 MIP Elbow and wrench tighten. Thread the Air Mixer onto the 3/8 Flared x 3/8 MIP Elbow and wrench tighten with air intake holes positioned horizontally and parallel with the floor.

**ASSEMBLY Continues**

**FIGURE 1**

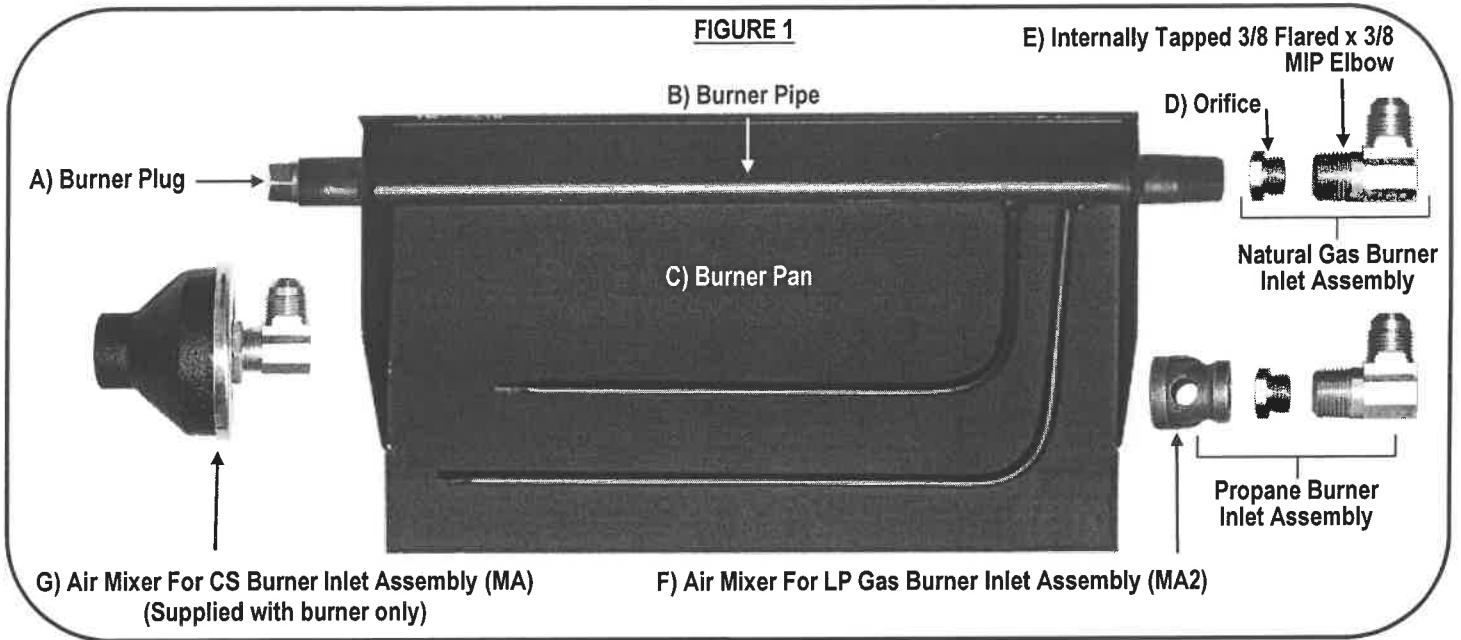

**STEP TWO: ATTACH PILOT (Figures 2 thru 5)**

**NOTE:** The following pilot attachment instructions apply to each burner model shown in Figures 2 thru 5.

With the **PILOT THERMOCOUPLE ASSEMBLY** (Figure 2A) attached to the **PILOT SUPPORT BRACKET** (Figure 2B), insert the **10-32 BOLTS** (Figure 2C) through the pre-drilled holes of the Pilot Support Bracket and into the threaded holes of the Pilot Thermocouple Assembly (Figure 2A). Tighten with flathead screwdriver.

**FIGURE 2 (F, FX,)**

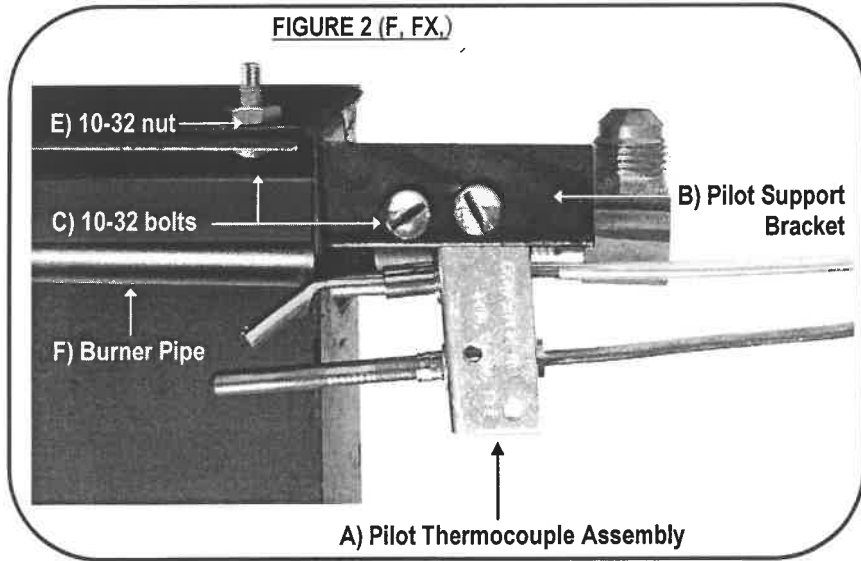

**FIGURE 3  
CS**

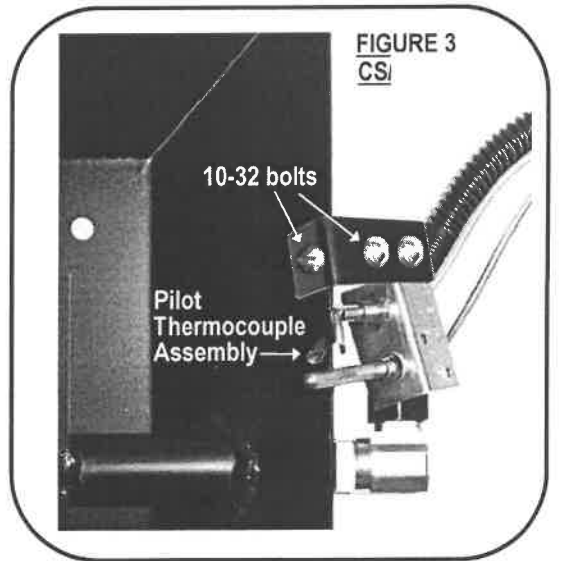

**FIGURE 4 (CXF Burner)**

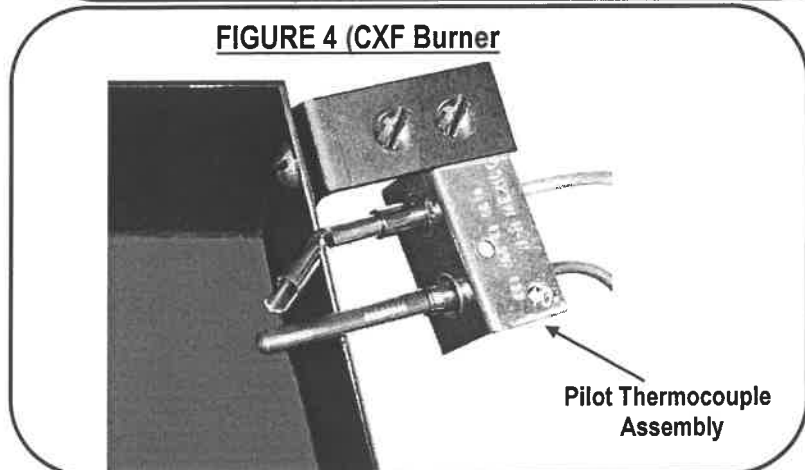

**FIGURE 5  
(TNA Burner)**

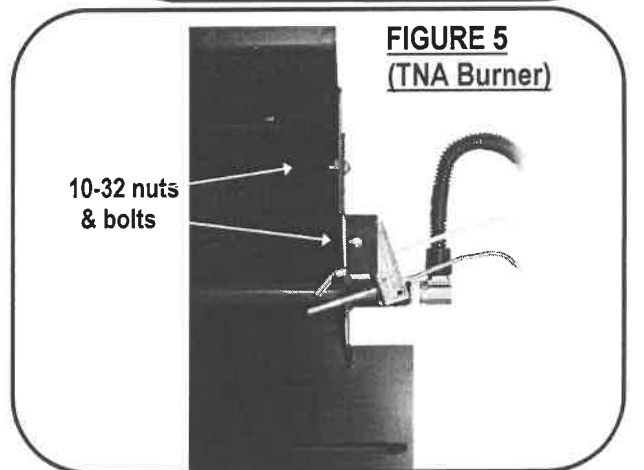

### LEFT SIDE GAS SUPPLY CONNECTION

Attach the Pilot Support Bracket (PB-1) to the left side of the burner pan using a 10-32 nut and bolt (Figure 7A), then place the Pilot Thermocouple Assembly over the bracket aligning the two screw holes (Figure 7b). Place the Thermocouple Heat Shield over the Thermocouple Assembly and bolt onto the Pilot Support Bracket using the supplied 10-32 nuts and bolts (Figure 7C).

**FIGURE 7**

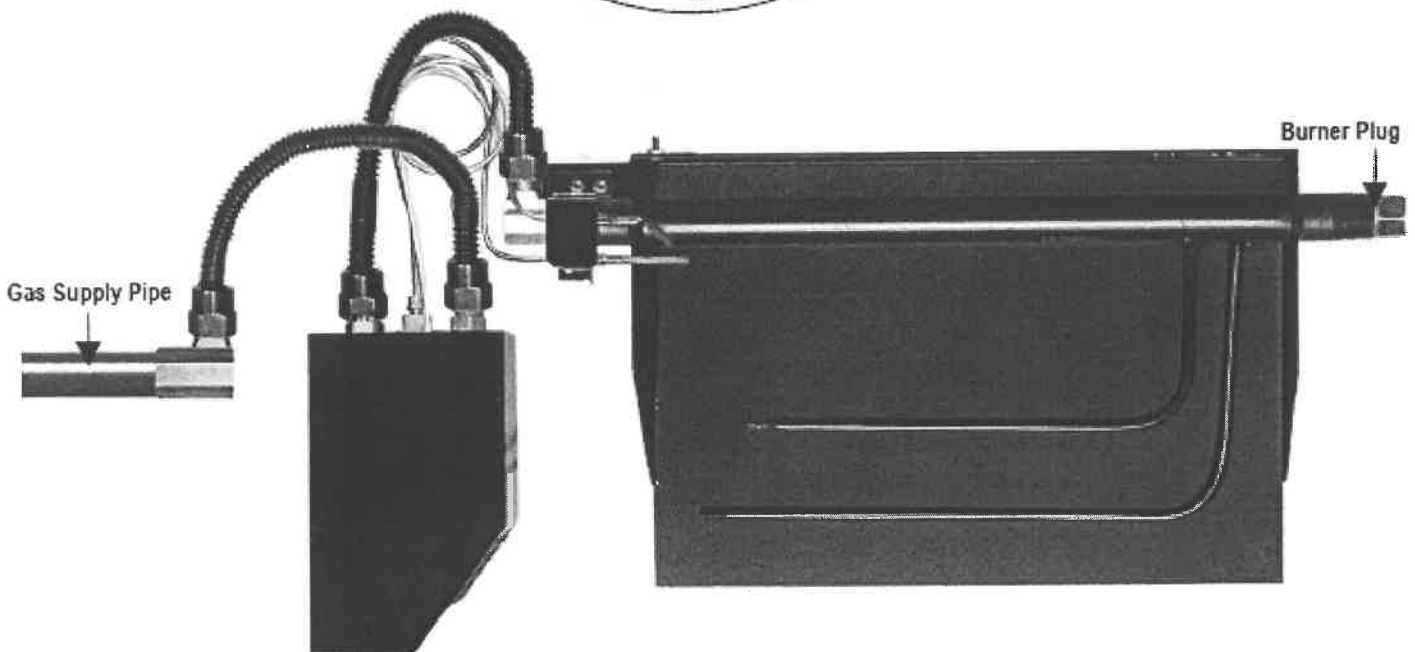
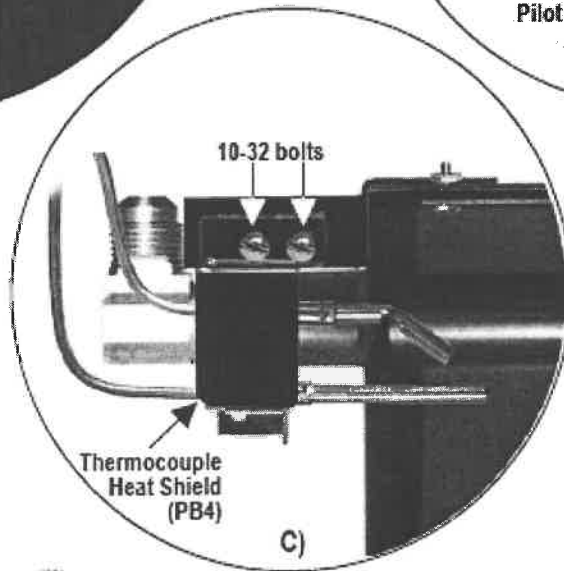
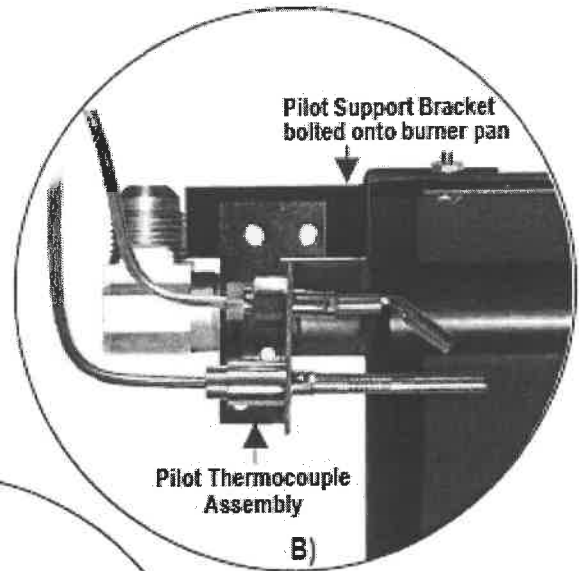
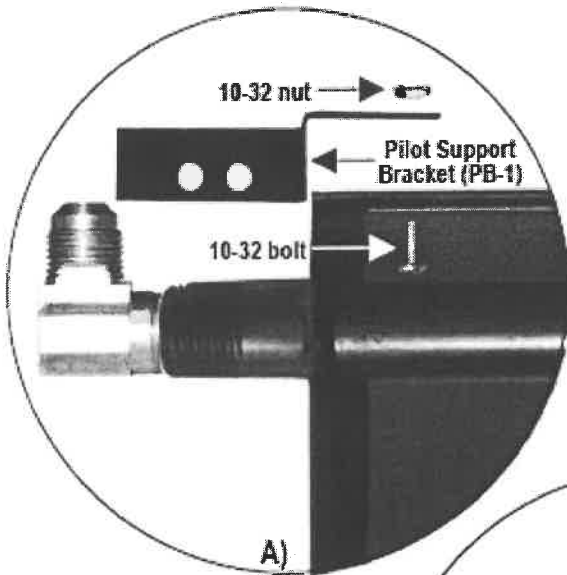

ASSEMBLY Continues

FIGURE 6

**STEP THREE: CONNECT BURNER AND PILOT GAS**

Connect 10" FLEX CONNECTOR (Figure 6A) between the flared ends of the VALVE OUTPUT 3/8 FLARED FITTING (Figure 6B) and the BURNER INPUT 3/8 FLARED 3/8 x MIP ELBOW (Figure C). Bend the 10" Flex Connector to the optimum Valve position (forward and to the side of the Burner pan, low to the floor).

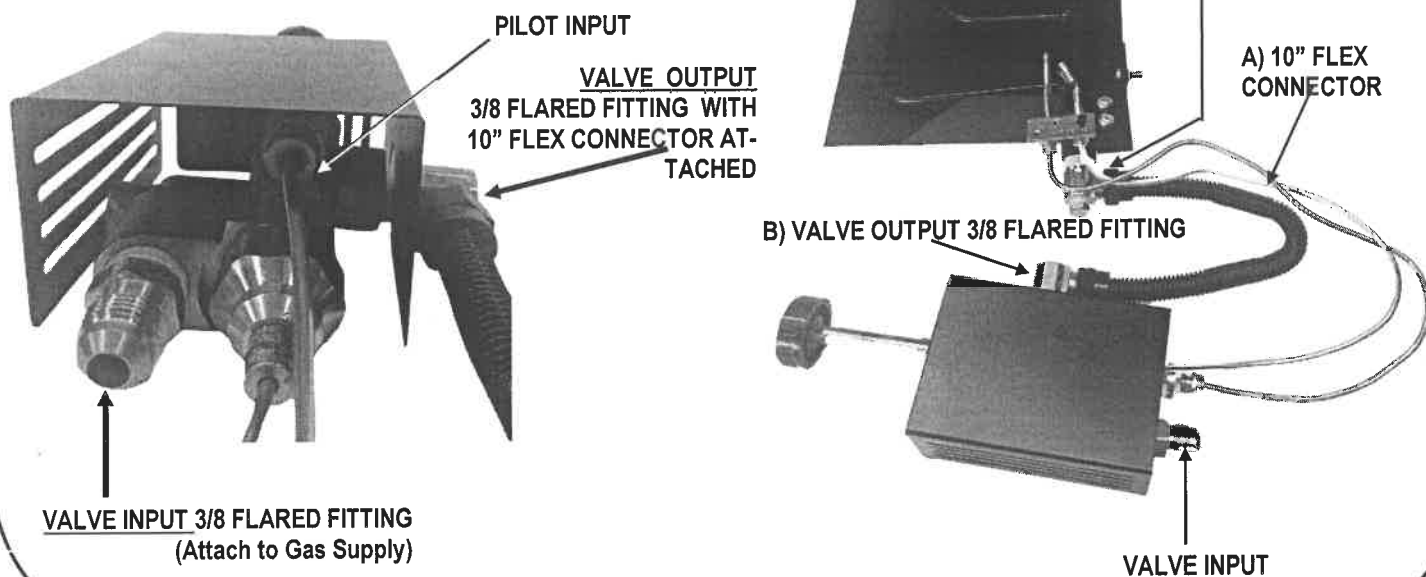

**IMPORTANT!**

**READ THESE WARNINGS PRIOR TO OPERATION**

**IMPORTANT!**

- **CHIMNEY DAMPER MUST BE WIDE OPEN!** The flue must vent all products of combustion. Damper and glass doors **MUST** be fully open before lighting or burning for proper ventilation and to prevent heat damage to the components which will not be covered under warranty.
- Your gas log set should be operated for the first 2-3 hours at a low flame setting to allow tempering of the refractory logs.
- **DO NOT REMOVE HEAT SHIELD** (Figure 7A). It is intended to prevent premature valve failure which will not be covered warranty. Replace immediately if removed for any reason.
- The Safety Control Valve must be protected to a maximum ambient temperature of 225° F. Excessive heat to the valve is indicated by melted plastic or wiring on the valve body and is not warrantable.
- Allow an adequate period of cooling after use before closing glass doors
- **NEVER** operate your gas log set with glass doors closed

### SUGGESTED FIREBOX LAYOUT AND REQUIRED PARTS

The Manual Safety Valve can be adversely affected by heat and must be placed as **far forward and to the side of the burner pan as possible** (Figure 7B). The example below shows an FX style burner.

**FIGURE 7**

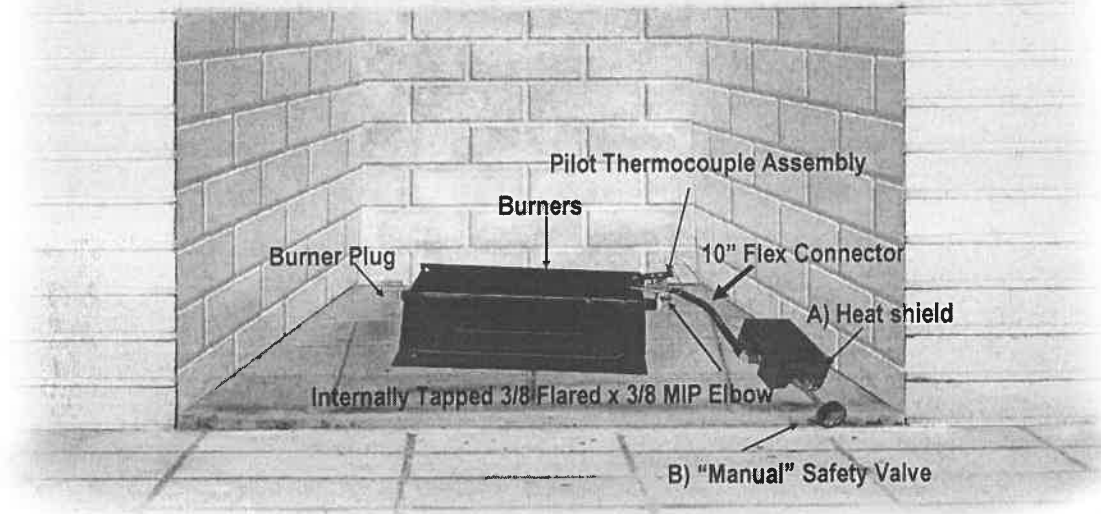

### **ATTENTION! Must read Carefully before operating SPK1**

The manual safety valve should be installed as far forward and away from the burner as possible

All piping and tube joints require pipe compound or plumbers tape. Be sure to test all connections for leaks prior to operating.

While attaching the pilot assembly, ensure it's correct position. (Page 2, figures 2, 3, 4 & 5)

Prior to testing the entire unit for operation be sure to fill the burner tray with Sand for Natural Gas or Volcanic Ash for Propane Gas. Attempting to test without burner medium can cause delayed ignition and damage to the burner tray which will not be covered under warranty.

Installing this control (SPK1), onto a burner other than a Rasmussen burner (F, FX, CS, CXF, TNA), will Void warranty.

## LIGHTING AND OPERATION

### STEP ONE: PILOT LIGHTING

1. Turn **VALVE KNOB** (Figure 8A) to "PILOT" position.
2. Depress and hold until air is bled and gas flows to Pilot (Figure 9A).
3. Light Pilot with a Match or Lighter.
4. Once Pilot is lit, continue to depress and hold until the Pilot flame remains lit (approximately 30 to 60 seconds).
5. If Pilot does not remain lit, depress and turn Valve Knob clockwise to "OFF" position and wait at least 5 minutes to allow gas to dissipate. Repeat steps 1 thru 4.

FIGURE 8 "Manual" SAFETY VALVE

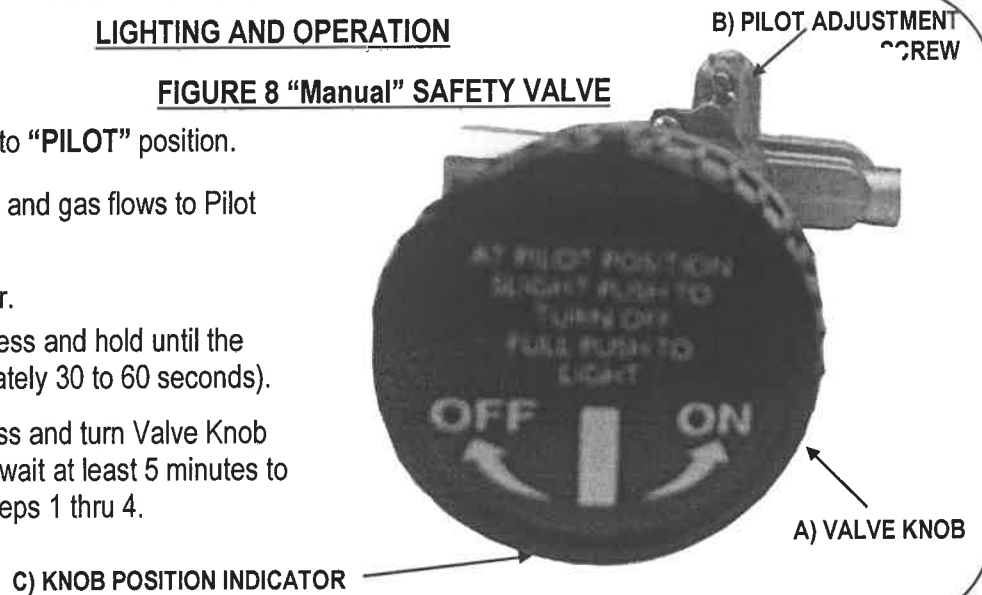
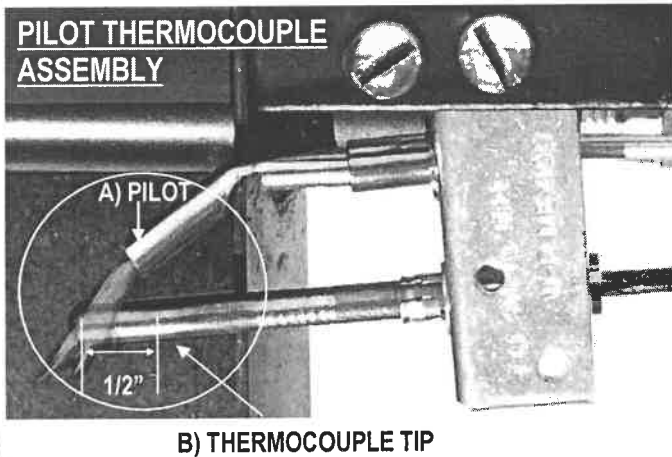

FIGURE 9

### STEP TWO: PILOT ADJUSTMENT



1. The Pilot flame should be steady, surrounding the **THERMOCOUPLE TIP** (Figure 9B).
2. If pilot flame adjustment is necessary, use a narrow long stem flathead screwdriver to turn **PILOT ADJUSTMENT SCREW** (Figure 8B) above.
3. Turn clockwise for less flame, counterclockwise for more.
4. If after pilot adjustment the burner begins to shutdown, re-adjust for a longer pilot flame.

### STEP THREE: BURNER OPERATION

1. Turn **VALVE KNOB** counter clockwise to "ON" position (Figure 10A).
2. Adjust the burner flame height by turning the valve knob clockwise to lower and counter-clockwise to raise up to full on.

**NOTE:** The **VALVE KNOB** has complete control of gas to the pilot and burner. It cannot be turned to "OFF" without first depressing dial to the "PILOT" position and then rotating clockwise to "OFF" (see figure 8A). During the heating season leave valve knob in "PILOT" position for convenience. Otherwise, turn to "OFF" position for any prolonged non-use.

FIGURE 10

