

"ACID HEARTH" WARNING

Cause of Acid Hearth

After new fireplace construction, the bricks are cleaned with "ACID" to remove excess mortar. Sometimes the acid is not thoroughly "Flushed out" with water by the workman. The acid remaining in the brick or stone will emit a gas that can decompose the protective coating on metal fixtures and cause oxidation and discoloration.

Customer Protection

You may experience fixtures that "rust"; however, this is neither your fault nor the fault of the product. This condition can continue for months unless corrective steps are taken. Although there is no guaranteed remedy, the following suggestions may help in neutralizing the condition:

1. Saturate the hearth with a mild solution of household ammonia. (Don't let it get on the adjacent hardwood floors or carpet.)
2. Rinse thoroughly with warm to hot water.
3. Follow with several cool rinses until the ammonia is removed.

Only after correction of "Acid Hearth" is it safe to replace fixtures. The responsibility for replacement should rest between the contractor and yourself.

LIMITED WARRANTY POLICY:

Manufacturer will replace any products or parts of products which are defective due to faulty materials or poor workmanship. The replacement of defective products will be without charge. The warranty extends only to the original consumer purchaser for one year from the date of original purchase. This warranty does not apply to (1) products damaged by accident, neglect, misuse or abuse, or (2) costs of removal or reinstallation of defective products. Manufacturer shall not be liable for incidental or consequential damages including, but not limited to, loss of profits or revenue, loss of use of the product or any associated product, cost of capital, cost of substituted products, services, downtime costs, or claims of customers of the purchaser for such damages. Some States do not allow the exclusion or limitation of incidental or consequential damages, so the above limitation or exclusion may not apply to you.

Any implied warranty of merchantability or fitness is limited to the one year duration of this written warranty. Some States do not allow limitations on how long an implied warranty lasts, so the above limitation may not apply to you.

Defective products, or parts of products, should be returned at your expense to the dealer from whom the product was purchased or to:

Any products returned for replacement must be accompanied by a return merchandise form, which will be provided upon request.

This warranty gives you specific legal rights, and you may also have other rights which vary from state to state.

ASSEMBLY AND INSTALLATION INSTRUCTIONS FOR RECESS STYLE FIREPLACE SCREENS

Wand or Baton Pull Patent No. Des. 348,314

If manual 4" Wand or 7" Baton Pulls have been ordered, they will be attached to the curtain mesh. Disregard the portions of the instructions pertaining to handpulls.

Pull Chain

If a Pull Chain option has been ordered, the entire screen will be pre-assembled. The instruction sections "B" and "C" should be disregarded.

CARE AND MAINTENANCE

To clean use a damp cloth. Wipe with a clean dry cloth.

CAUTION: Do not use any abrasive metal polish on the Faceplate or damage to the lacquer coating may occur.

To insure smooth operation of the curtain, lubricate the backrod occasionally with paraffin wax or a light oil.

SEE "ACID HEARTH" WARNING ON BACK PAGE.

Figure 1

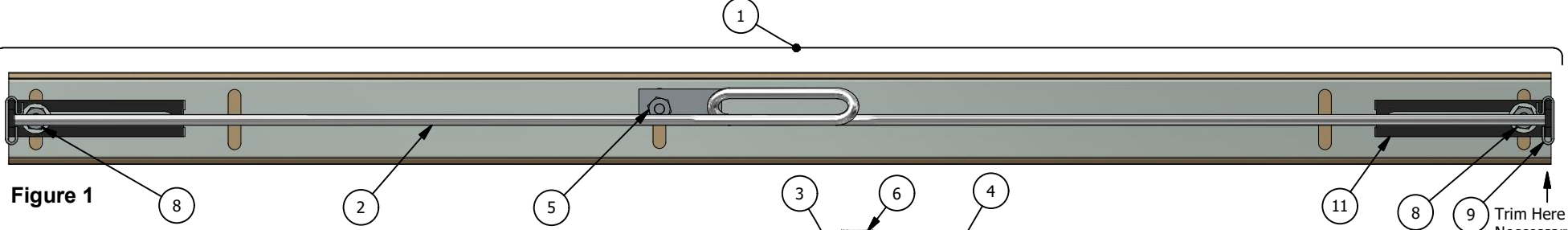

A. VERIFY DIMENSIONS

Check Hanger Assembly width and Backrod length to be sure they will fit within the fireplace opening. If necessary, trim the Hanger Assembly and Backrod to fit, or chip the mortar and stone to clear. (Fig. 1) Do not remove the protective coating from the Faceplate until the installation is complete.

B. TO ASSEMBLE CURTAIN ON BACKROD

1. Lay the fireplace screen parts out as shown in Fig. 1. Notice the location of the two closely spaced rings (3) on each half of the curtain mesh. They indicate which edge of the curtain must be placed at the center of the Hanger. Place the Spacer Spring between the second and third ring. The Wand (7) is factory installed between the third and fourth ring as shown in Fig. 2.

2. Remove the Backrod (2) from the Hanger Assembly (1) by loosening the center hex nut (5) and the end hex nuts (8). See Fig. 3.

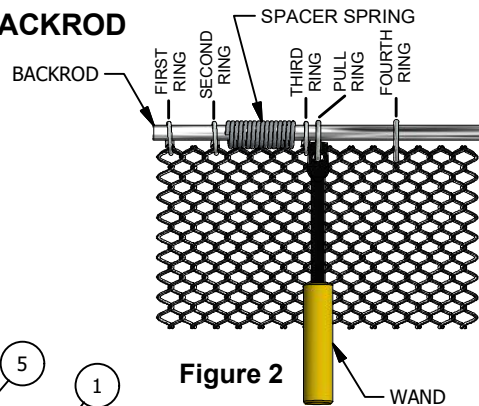

Figure 2

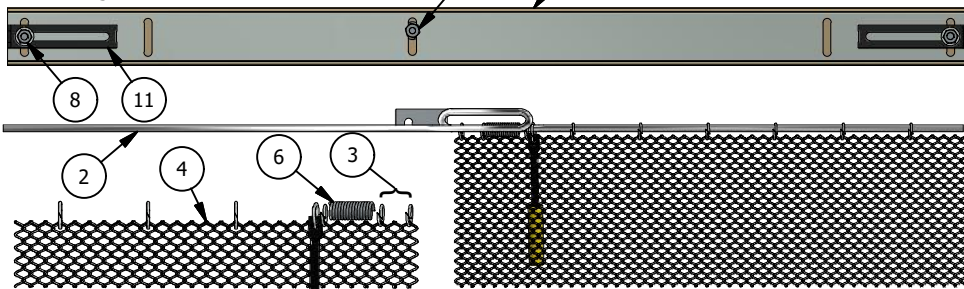

Figure 3

3. Starting at the center edge of the curtain, slide the Backrod (2) through the first two rings (3), the Spacer Spring (6), the third ring, the pull ring with Wand (7), then the fourth and all remaining rings, except the last ring (10) which will be hooked to the Retaining Clip (9) See Fig. 5.

NOTE: For pleated curtains see section "C".

4. With both curtains attached, replace the Backrod (2) on the Hanger Assembly (1). Tighten the center hex nut (5) and the end hex nuts (8). Attach each end ring (10) to Retaining Clip (9) See Fig. 5.

C. PLEATED CURTAINS

Beginning with the fourth ring (4) from the center, turn each ring 1/2 turn to the left, then slide it on the Backrod (2). Do not turn the last ring (10). It remains loose so it can be hooked to the Retaining Clip (9).

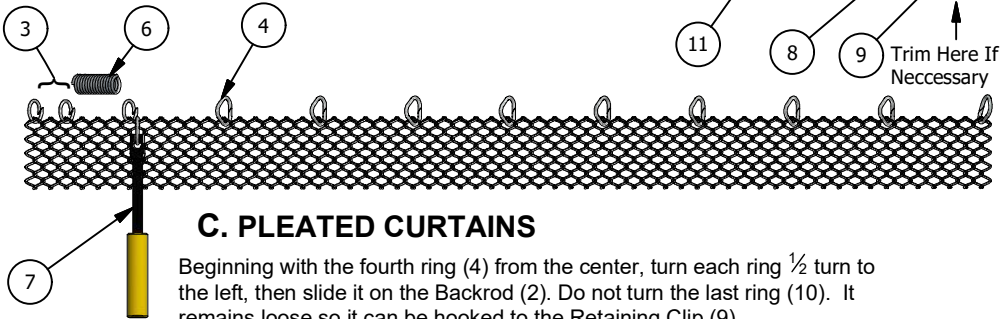

D. LINTEL CLAMP INSTALLATION

1. Attach the Lintel Clamp Assembly (12) loosely to the Hanger Assembly (1) by using the hex nut (14).
2. Fasten each Lintel Clamp Assembly (12) to the Lintel Bar on the inside of the fireplace opening with the Thumbscrew (13). Loosen the phillips screw (15) in the Lintel Clamp Assembly (12) and adjust the Hanger Assembly (1) until it is flush with the face of the fireplace. When finished, be sure the phillips screw (15) and the Thumbscrew (13) are tight.
3. When the installation is complete remove the protective coating from the Faceplate.

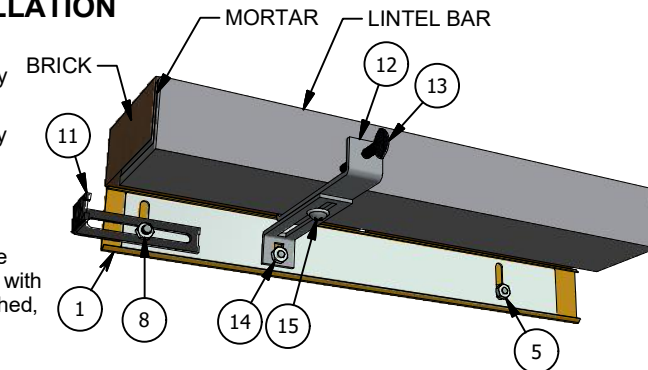

Figure 4

E. TO ADJUST MESH CURTAIN HEIGHT

1. The bottom edge of the mesh curtain should be approximately 1/4" above the hearth. Adjust the mesh height by loosening the center hex nut (5) and the end hex nuts (8), then raise or lower the Backrod (2) and the Hanger Assembly (1). See Fig. 1. With the height set, tighten the hex nuts.

F. TO INSTALL THE LINTEL BRACKET WITH THREAD CUTTING SCREWS

Use this method to install the Lintel Bracket to the Lintel Bar without using the Lintel Clamp.

1. Hold the Hanger Assembly (1) in proper position and mark the Lintel Bar through the slotted Lintel Brackets with a red pencil or chalk.
2. Drill holes in the Lintel Bar using a 7/32"Ø or No. 1. drill bit for each Lintel Bracket.
3. Fasten the Lintel Brackets to the Lintel Bar with the supplied Thread Cutting Screws.

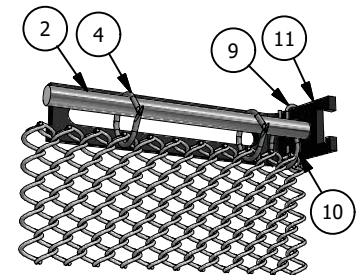

Figure 5